

# FONTAINE RENEGADE™ LXT40 EXTENDABLE LOWBED

FIND OUT WHY  
MORE FLEETS  
AND OWNER  
OPERATORS  
RUN WITH  
FONTAINE® THAN  
EVER BEFORE

*Renegade™*



## Fontaine Renegade LXT40 Extendable Lowbed

- MECHANICAL, REMOVABLE GOOSENECK WITH FIFTH WHEEL GUIDE ROLLERS
- TRUE 40 TON CAPACITY IN 16'
- 81" SWING RADIUS WITH 9' 10" OVERALL GOOSENECK LENGTH
- FLAT, LEVEL DECK WITH 29' CLEAR DECK LENGTH IN THE CLOSED POSITION
- FRONT OF DECK IS SLOPED AND FEATURES TRACTION CLEATS FOR EASIER LOADING AND UNLOADING
- AIR-RIDE SUSPENSION WITH AUTOMATIC AND MANUAL CONTROLS
- COMBINATION FIGURE-EIGHT PLATE PROVIDES 50" AND 52" LOADED FIFTH WHEEL HEIGHTS TO EASILY ACCOMMODATE A WIDE VARIETY OF TRUCKS



# RENEGADE™ LXT40 EXTENDABLE SPECIFICATIONS

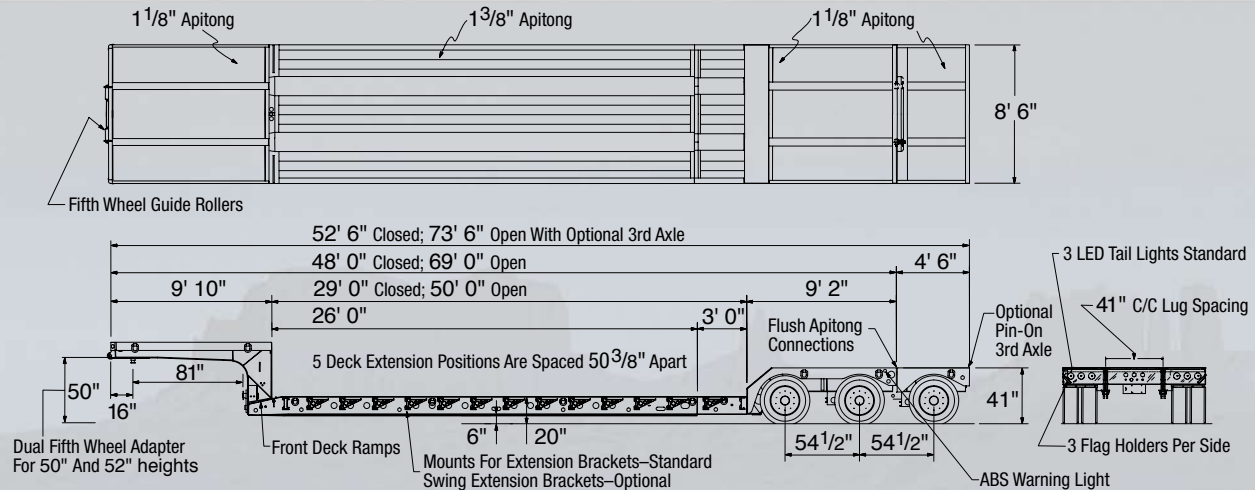

## MAIN BEAMS

- All main longitudinal members fabricated with 100 KSI minimum yield steel flanges with 50,000 lb webs

## CAPACITY

- 40 tons in 16'—GAWR and tire ratings determine legal payloads

## LOAD BASE

- 16' rigid 2-point load centered in deck

## LOADED FIFTH WHEEL HEIGHT

- Combination figure-eight plate provides 50" and 52" loaded height to easily accommodate a wide variety of trucks

## GOOSENECK

- Mechanical removable design with fifth wheel guide rollers
- Full-width gooseneck platform for greater loading space with 1 1/8" apitong or equivalent flooring
- J560 7-pin electrical connector

## TELESCOPIC DECK DESIGN

- 20" loaded deck height with 6" ground clearance
- Front of deck is sloped and features traction cleats to make loading and unloading easier
- Full-width 1 3/8" nominal apitong or equivalent flooring
- Mounting brackets to accommodate optional extension brackets

## BOGIE DESIGN

- Covered rear bogie platform with 1 1/8" apitong or equivalent flooring
- Fixed deck-to-bogie connection with full-width bogie ramp
- Connections for future axle (including air and electrical)

## AXLES

- 2 heavy-duty axles with 54 1/2" spread
- Air/electrical connections in place for easy third axle connection
- 25,000 lb nominal capacity per axle
- Tapered spindle axles, automatic slack adjusters and spring brakes

## 2S/2M ANTILOCK BRAKE SYSTEM

- ABS wired to center pin of 7-way socket
- Electronic sensors at every wheel end for greater braking control
- Virtually eliminates tire flat-spotting

## BRAKES

- Spring brakes (2 axles)
- 16 1/2" x 7" with 5 1/2" autoslacks
- Heavy-duty brake drums, outboard mount
- Quick change replacement feature saves repair time
- Automatic slack adjusters maintain positive braking action

## HUBS

- Hub-piloted 10-stud mount for increased capacity and durability
- Outboard cast drums save time and cost on brake repairs

## WHEELS/TIRES

- 8.25 x 22.5 steel disc wheels with 255/70R 22.5 H-ply tires

## SUSPENSION

- Unitized air-ride suspension with automatic and manual controls
- Suspension mount is engineered, reinforced and braced to virtually eliminate frame cracking

## ELECTRICAL SYSTEM

- Sealed harness for maximum corrosion resistance
- DOT sealed beam with LED lights
- 7 marker lights per side including mid-turn signal
- 3 stop, tail and turn lights per side on rear

## PROTECTIVE COATING

- Highest quality 2-part polyurethane enamel fights corrosion to extend the life of your trailer
  - Shot blasted and cleaned prior to painting
  - Primed for better paint adhesion

## LASH RINGS

- 9 pair (18 total), bent D-Ring design ensures longer chain life and better payload securement

## FLAG HOLDERS

- 3 pair (6 total)

## ACCENT PACKAGE

- Aluminum fenders at rear of gooseneck
- Stainless steel bumper insert
- Stainless steel laser-cut Renegade logo panel

## ESTIMATED EMPTY WEIGHT W/O

OPTIONS: 22,150 lbs ± 3%



Specifications subject to change without notice.  
Photos show some optional equipment.



Fontaine Trailer Company

430 Letson Road • P.O. Box 619 • Haleyville, AL 35565 • 800-821-6535 • fax 205-486-8985 • www.fontainetrailer.com